

## Low-Voltage Electronic Speech Circuit with Dialer Interface

### Description

The U4055B electronic speech circuit is a linear integrated circuit for use in telephone and other line fed terminal equipment. It replaces the common speech circuit with carbon microphone, hybrid transformer,

sidetone equivalent and ear protection rectifiers. A low-cost electrodynamic transducer is used as the earphone. It contains all components necessary for amplification of signals and adaption to the line.

### Features

- An electronic circuit replaces the microphone hybrid transformer
- Symmetrical input for dynamic or piezo microphone
- High performance through the use of dynamic transducers as the earphone (non-linear distortion  $\leq 2\%$ )
- Automatic line loss compensation
- DTMF interface with muting
- Supply voltage for dialer
- High range of line feeding current
- Input resistance independent of line current and sidetone suppression circuit.
- Built-in ear protection by earphone voltage limiter
- Operation possible from 8 mA

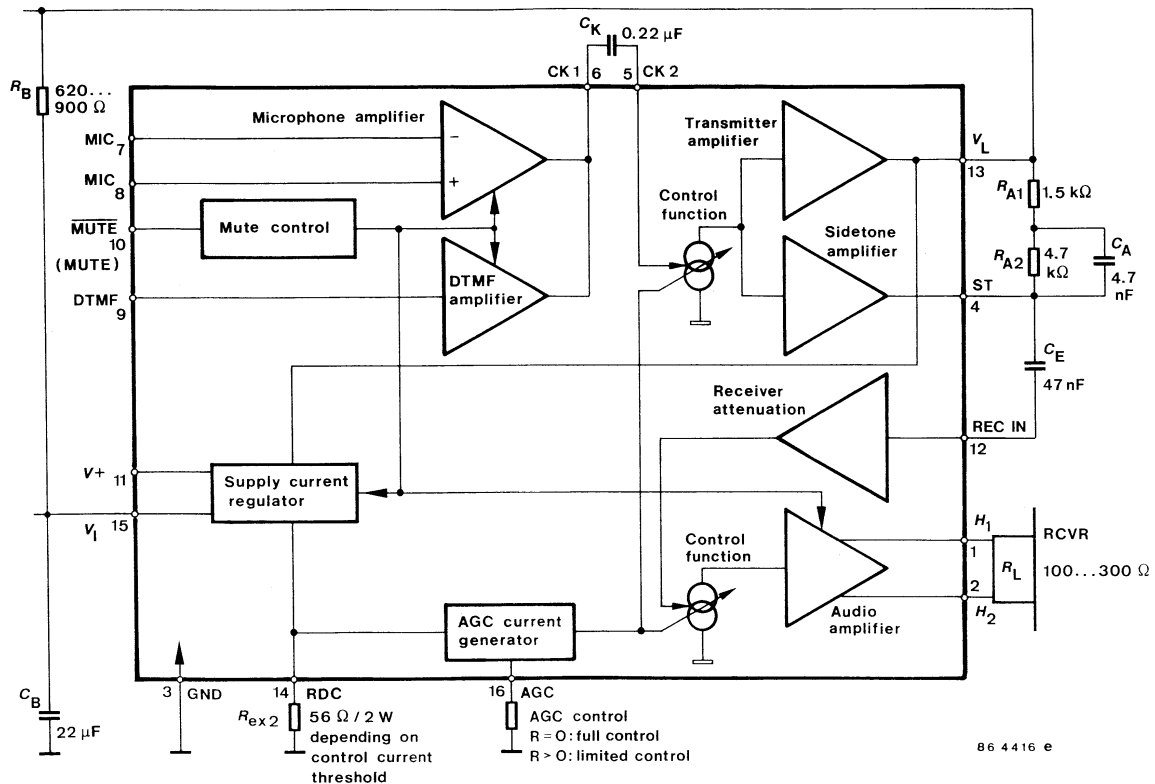

**U4055B1:** High level mute; **U4055B:** Low level mute

Figure 1 Block diagram and pin connection

### Pin Description

Pin	Symbol	Function
1, 2	H <sub>1</sub> and H <sub>2</sub>	The push-pull complementary outputs of the receive amplifier. Dynamic transducers with a minimum impedance of 100 Ω can be directly driven by these outputs.
3	GND	Ground.
4	ST	The output of the sidetone cancellation signal, which requires a balanced impedance of 8–10 times the subscribers line impedance to be connected to Pin 13.
5	CK2	Input to the line output driver amplifier. Transmit a.g.c. applied to this stage.
6	CK1	The transmit pre-amp output respective of the DTMF output which is normally capacitively coupled to Pin 5.
7, 8	MIC 1, MIC 2	Inputs of symmetrical microphone amplifier with high common mode rejection ratio.
9	DTMF IN	The DTMF input has an internal resistor connected to ground. It provides the load resistor for the emitter of a CMOS DTMF generator. This input is only active when MUTE (Pin 10) is pulled high or MUTE is pulled low.
10	MUTE or $\overline{\text{MUTE}}$	The MUTE input must be pulled at least at 1.5 V (MUTE) or at less than 0.5 V ( $\overline{\text{MUTE}}$ ) to mute the MIC Amp. and Audio Amp. and enable DTMF IN.

Pin	Symbol	Function
11	V+	Regulated output voltage of 2.7 V for biasing a DTMF generator activated by MUTE.
12	REC IN	The receive amplifier input. The receiving amplification is regulated of an a.g.c.
13	V <sub>L</sub>	Positive supply voltage input to the device. This input should be connected to the positive output of the polarity guard. The current through this pin is modulated by the transmit signal.
14	R <sub>DC</sub>	An external resistor (2 W) is required from this pin to GND to control the dc input impedance of the circuit. It has a nominal value of 56 Ω for low voltage operation. Values up to 100 Ω may be used to increase the available transmit output voltage swing at the expense of low-voltage operation.
15	V <sub>I</sub>	This internal voltage bias line must be connected to V <sub>L</sub> via an external resistor, R <sub>B</sub> , which dominates the ac input impedance of the circuit and should be 620 Ω for an 600 Ω input impedance or 910 Ω for a 900 Ω input impedance.
16	R <sub>AGC</sub>	The range of transmit and receive gain variations between short and long loops may be adjusted by connecting a resistor R <sub>EX1</sub> from this pin to Pin 3 (GND). This pin can be left open to set a.g.c. out of action.

## Pin Connection

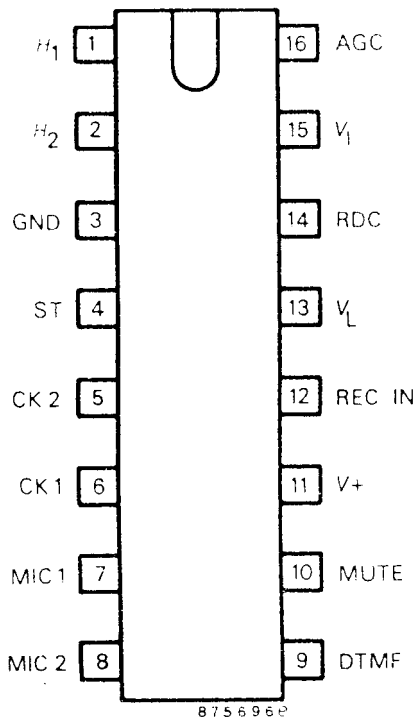

Figure 2

## Absolute Maximum Ratings

Reference point Pin 3, unless otherwise specified.

Parameters	Symbol	Value	Unit
Line current	$I_L$	200	mA
DC line voltage, $t_p = 3$ ms Pin 13	$V_L$	20	V
Power dissipation, $I_L = 100$ mA	$P_{tot}$	560	mW
Junction temperature	$T_j$	150	°C
Ambient temperature range	$T_{amb}$	-28 to +80	°C
Storage temperature range	$T_{stg}$	-55 to +150	°C

## Thermal Resistance

Parameters	Symbol	Value	Unit
Junction ambient	$R_{thJA}$	85	K/W

## Electrical Characteristics

Reference point Pin 3, cable equivalent =  $I = 1 \text{ km}$ ,  $\varnothing 0.5 \text{ mm}$ ,  $R' = 184 \Omega$ ,  $C' = 37 \text{ nF}$ ,  $f = 1300 \text{ Hz}$ ,  $0 \text{ dBm} = 775 \text{ mV}_{\text{rms}}$ ,  $R_{\text{DC}} = 56 \Omega / 2 \text{ W}$ ,  $T_{\text{amb}} = 25^\circ\text{C}$ , unless otherwise specified.

Parameters	Test Conditions / Pins	Symbol	Min.	Typ.	Max.	Unit
Line voltage	$I_L = 8 \text{ mA}$	$V_L$	1.8	2.1	2.6	V
	$I_L = 20 \text{ mA}$		3.0	3.3	3.6	V
	$I_L = 30 \text{ mA}$		3.6		4.5	V
	$I_L = 73 \text{ mA}$ , see figure 4		7.7		9.7	V
<b>Transmit and sidetone</b> see figure 5						
Input resistance	Pin 7 – 8	$R_i$	7	10	13	k $\Omega$
Gain	$I_L = 30 \text{ mA} \cong l = 5 \text{ km}$ adjustable with $R_{\text{AGC}}$ $I_L = 30 \text{ to } 73 \text{ mA} \cong l = 5 \text{ km to } 0 \text{ km}$	$G_s$	57	59	61	dB
		$\Delta G_s$	-7		-9	dB
Noise at line weighted psophometrically	$I_L = 73 \text{ mA} \cong l = 0 \text{ km}$ $V_{\text{MIC}} = 0 \text{ V}$	$n_o$		-70	-68	dBm
Sidetone reduction	$I_L \geq 20 \text{ mA}$	$G_{\text{STA}}$	10	15	20	dB
<b>DTMF-Amplifier</b> see figure 6						
Input resistance	Pin 8 – 3	$R_D$	8	10	13	k $\Omega$
DTMF Gain	$I_L = 30 \text{ mA} \cong I = 5 \text{ km}$ $R_{\text{ex1}} = 0$ adjustable with $R_{\text{ex1}}$ $I_L = 31 \text{ mA to } 78 \text{ mA} = l = 5 \text{ km to } 0 \text{ km}$	$G_D$	9		13	dB
		$\Delta G_D$	-7		-9	dB
Volume range $d \geq 5\%$		$V_0$	1			$V_{\text{RMS}}$
<b>Receiving amplifier</b> see figure 4						
Input resistance	Pin 12 – 3	$R_i$		50		k $\Omega$
Gain	$R_{\text{HH}} = 300 \Omega$ , $I_L = 30 \text{ mA} \cong l = 5 \text{ km}$ $R_{\text{HH}} = 300 \Omega$ adjustable with $R_{\text{AGC}}$ , $I_L = 31 \text{ mA to } 78 \text{ mA}$ $l = 5 \text{ km to } 0 \text{ km}$	$G_R$	-1	-3	-5	dB
		$\Delta G_R$	-5	-6	-7	dB
Receiving noise at earphone weighted psophometrically	$I_L = 78 \text{ mA} = l = 0 \text{ km}$ $S_2 = 0$	$n_i$		-80	-71	dBm
Gain change when muted	$I_L \geq 20 \text{ mA}$	$G_{\text{RM}}$	15	20	24	dB
Output saturation threshold	$I_L \geq 20 \text{ mA}$	$V_0$	0.8	1	1.5	$V_{\text{pp}}$
<b>MUTE or MUTE-input</b>						
MUTE-input current	Pin 9 = 0 V	$\overline{I_M}$	20	50	80	$\mu\text{A}$
MUTE off input voltage		$V_{\text{Moff}}$	1.5			V
MUTE on input voltage		$V_{\text{M on}}$			0.3	V
MUTE-input current	Pin 9 = 1.5 V	$I_M$	10	20	30	$\mu\text{A}$
MUTE off input voltage		$V_{\text{M off}}$			0.3	V
MUTE on input voltage		$V_{\text{M on}}$	1.5			V
<b>Supply voltage</b> see figure 4						
Output voltage	$I_L \geq 20 \text{ mA}$ MUTE or MUTE switched off	$V_+$	3		6.1	V
	switched on Pin 10		2.5	2.9	3.1	V
Output current	$I_L \geq 20 \text{ mA}$ MUTE or MUTE switched off	$I_+$			30	$\mu\text{A}$
	switched on Pin 10		1			mA

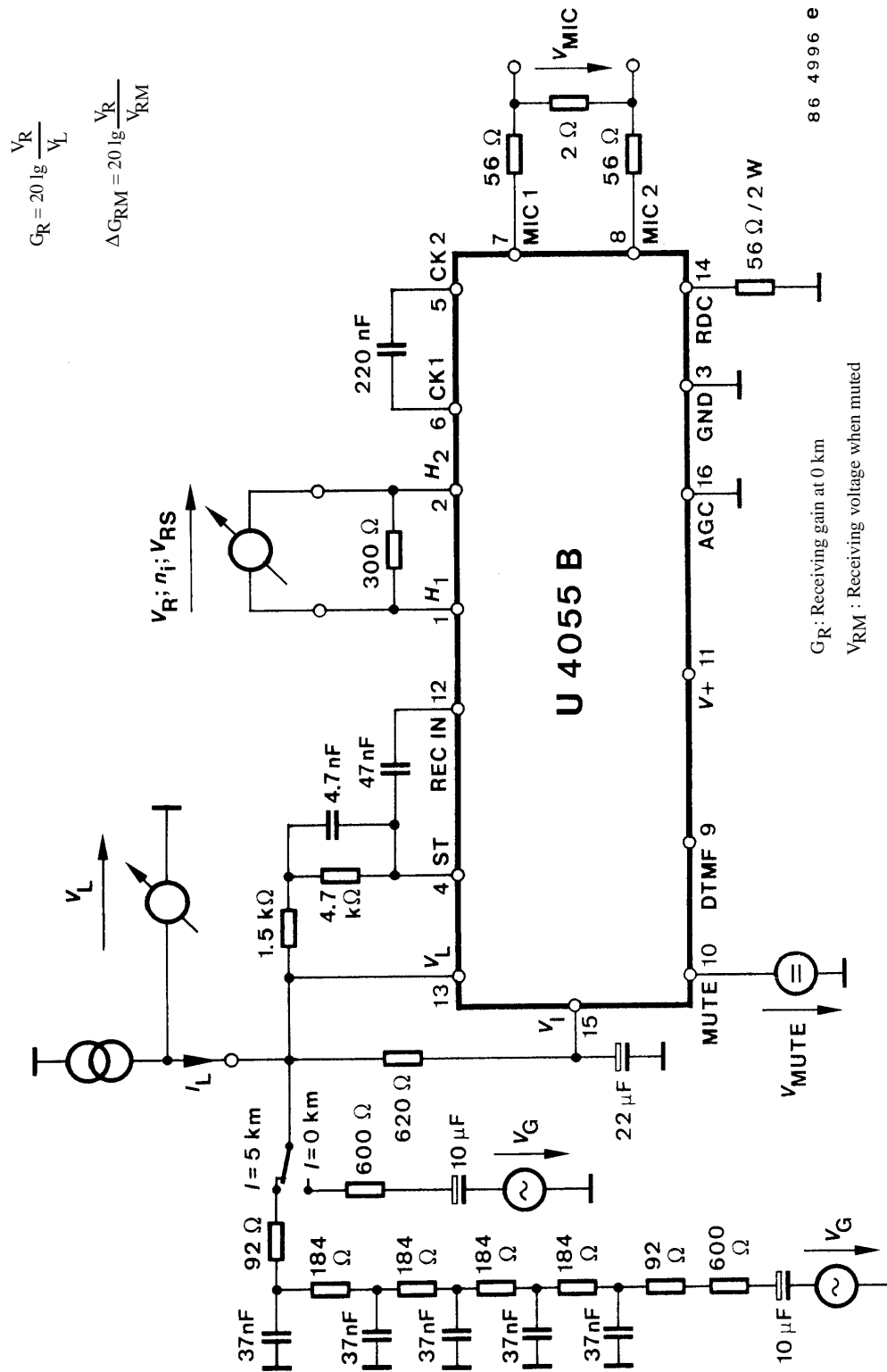
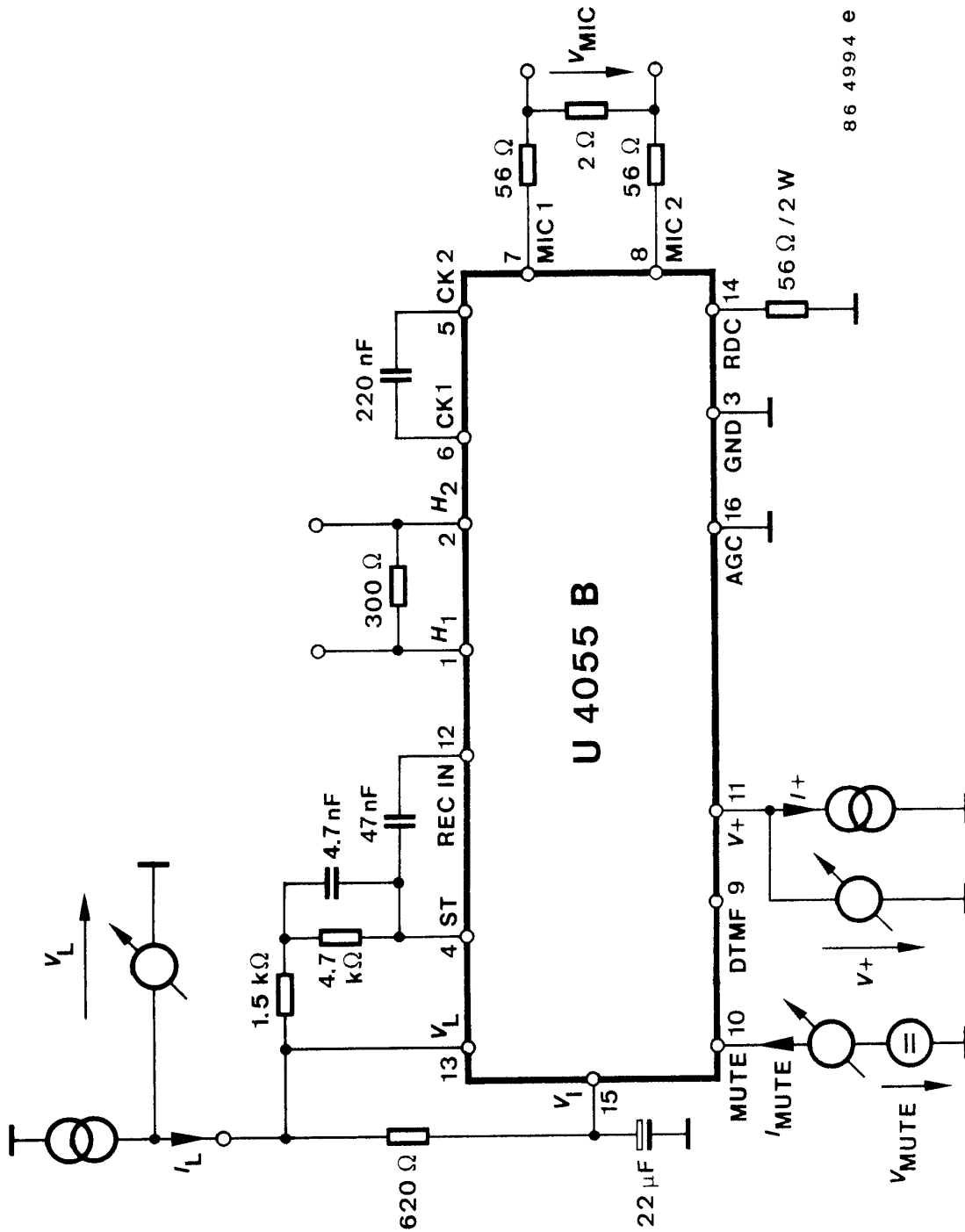

Figure 3 Receiving amplifier

# U4055B/U4055B1

# TEMIC

TELEFUNKEN Semiconductors



8 6 4 9 9 4 e

Figure 4 Line and supply voltage characteristics

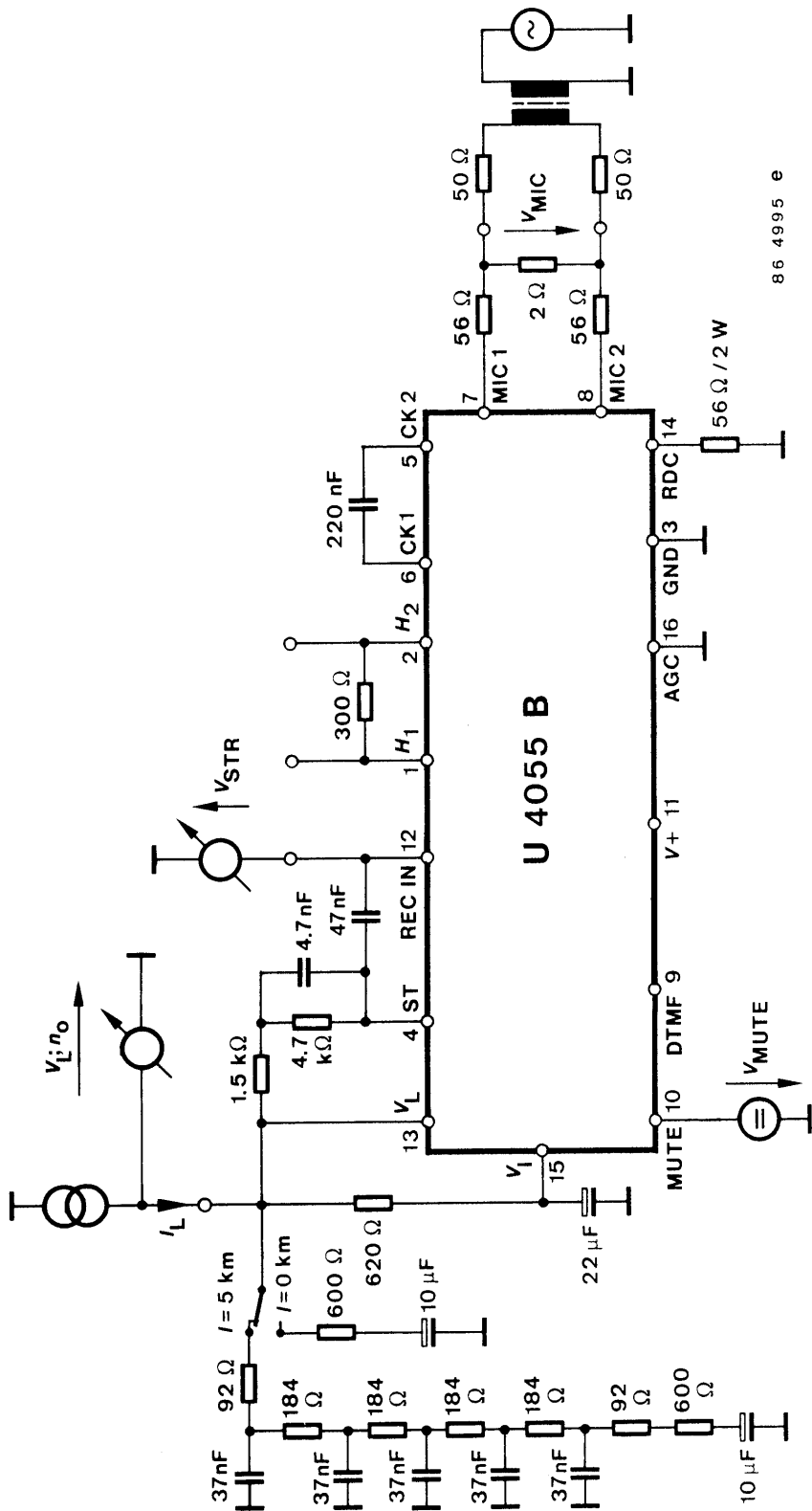

86 4995 e

$G_S$  : Sending gain at 0 km  
 $G_{S5}$  : Sending gain at 5 km  
 $G_S = 20 \log \frac{V_L}{V_{MIC}}$   
 $\Delta G_S = G_S - G_{S5}$

Measurement point pin 13  
 $\Delta G_S$  Typical = -7.5 dB

Figure 5 Transmitting amplification

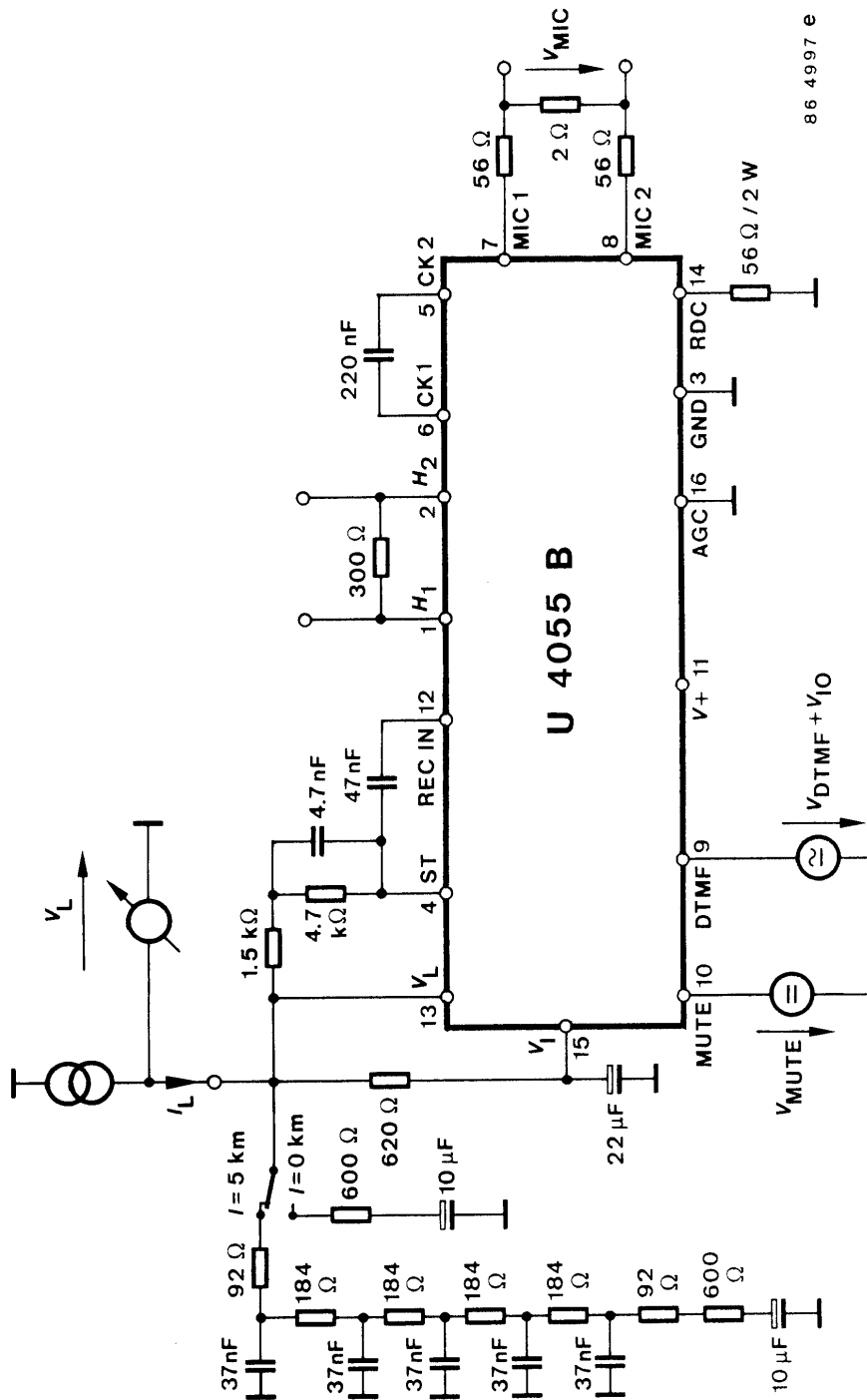

86 4997 e

Volume range  
 (dB  $\leq 5$  %) min  $V_O = 850$  mVrms  
 $G_D = 20 \log \frac{V_L}{V_{DTMF}}$

Figure 6 DTMF amplifier





## Ozone Depleting Substances Policy Statement

It is the policy of **TEMIC TELEFUNKEN microelectronic GmbH** to

1. Meet all present and future national and international statutory requirements.
2. Regularly and continuously improve the performance of our products, processes, distribution and operating systems with respect to their impact on the health and safety of our employees and the public, as well as their impact on the environment.

It is particular concern to control or eliminate releases of those substances into the atmosphere which are known as ozone depleting substances (ODSs).

The Montreal Protocol (1987) and its London Amendments (1990) intend to severely restrict the use of ODSs and forbid their use within the next ten years. Various national and international initiatives are pressing for an earlier ban on these substances.

**TEMIC TELEFUNKEN microelectronic GmbH** semiconductor division has been able to use its policy of continuous improvements to eliminate the use of ODSs listed in the following documents.

1. Annex A, B and list of transitional substances of the Montreal Protocol and the London Amendments respectively
2. Class I and II ozone depleting substances in the Clean Air Act Amendments of 1990 by the Environmental Protection Agency (EPA) in the USA
3. Council Decision 88/540/EEC and 91/690/EEC Annex A, B and C (transitional substances) respectively.

**TEMIC** can certify that our semiconductors are not manufactured with ozone depleting substances and do not contain such substances.

**We reserve the right to make changes to improve technical design and may do so without further notice.**

Parameters can vary in different applications. All operating parameters must be validated for each customer application by the customer. Should the buyer use TEMIC products for any unintended or unauthorized application, the buyer shall indemnify TEMIC against all claims, costs, damages, and expenses, arising out of, directly or indirectly, any claim of personal damage, injury or death associated with such unintended or unauthorized use.

TEMIC TELEFUNKEN microelectronic GmbH, P.O.B. 3535, D-74025 Heilbronn, Germany  
Telephone: 49 (0)7131 67 2831, Fax number: 49 (0)7131 67 2423